



Technical Documentation

LAS 260.1

Version 06



Contents

Description of Product Series	3
Features – LAS 260.1 Extraction and Filtration Unit.....	3
Equipment	4
Technical Data – LAS 260.1	8
Characteristic Curves and Operating Modes.....	9
LAS Series – Laser Smoke	11
Areas of Application.....	11
Operating Principle.....	11
Device Variant.....	12
LAS 260.1 FK.....	12
Accessory items	13
DN50 extraction system.....	13
DN80 extraction system.....	14
DN100 exhaust air system.....	15
Interface accessories.....	15
Spark pre-separator*	15
Secondary filter U15.....	15
Replacement filter	16
Technical Illustration	17



Description of Product Series

The **LAS 260.1** series is used for collection and filtration of dry and non-combustible dusts in air mixtures that are not potentially explosive and are produced during laser machining.

Suitable multi-stage filtration systems are available **for all industrial applications** to deal with different configurations of harmful or unwanted substances.

The harmful and unwanted substances produced in the relevant customer process are collected via collection elements immediately at the point of creation and then filtered by the units in the LAS 260.1 series. Individual filters are carefully combined for the individual application process to achieve the **highest separation rates**. The underlying filtration technology uses particle separation techniques for dusts and adsorption techniques for gaseous substances.

Thanks to the high degree of purification, the filtered clean gas can be directed back to the working space (**recirculated air mode**). As a result there are no thermal losses. If recirculated air mode is not required, the configuration can be changed so that the outlet air is discharged rather than fed back into the process. This can be set up very easily by installing the pipe nozzle that is included with the unit. The filtered clean gas is then directed into an **air outlet** system.

The units in the LAS 260.1 series can be optionally combined with a **wide range of accessories**. Suitable accessory parts can be selected based on the individual requirements of the customer.

Features – LAS 260.1 Extraction and Filtration Unit

- Available with innovative **ULT ProSight®** control
- **Interchangeable filter system** – for safe removal with minimal contamination risk
- **Low-cost replacement filters** thanks to multi-stage filtration system with cost-effective pre-filter elements with high absorption capacity
- Suitable for a **wide range of applications**: the blower used is suitable for high vacuums and high volumetric flow rates
- **Low energy consumption** thanks to energy-efficient electronics
- Electrical equipment designed for **global use**: suitable for operation at 110 V - 240 V
- All electrical components compliant with UL and CE standards
- Integrated soundproofing ensures extremely **quiet operation**
- Robust sheet steel enclosure **powder coated**
- **Mobile unit** with casters
- All interfaces are rear-mounted
- Operating and control elements are located on the front





Equipment

Figure 1: Front operating panel with ULT ProSight control

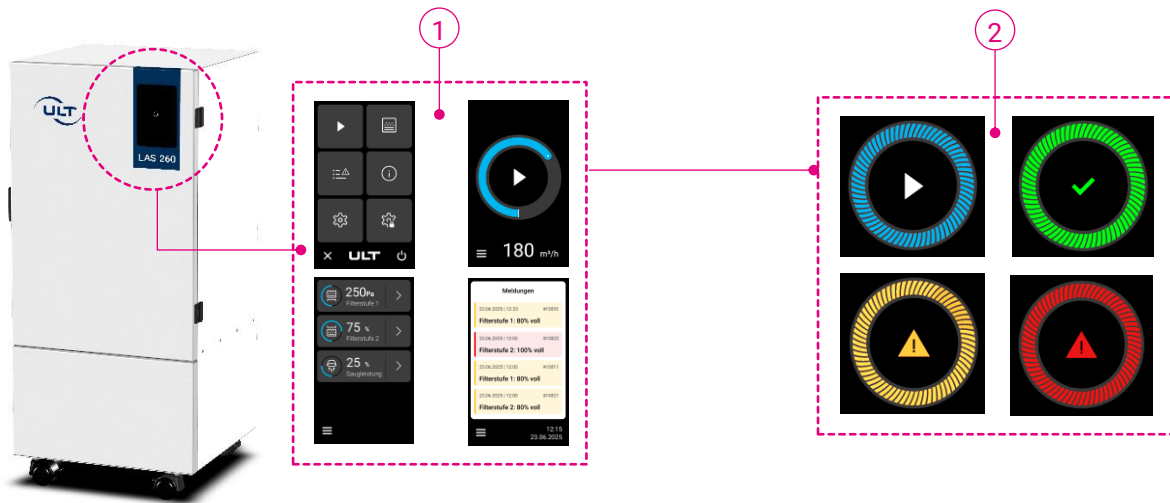

1 HMI display

Available functions:

- Selection of different languages (DE, EN, FR, CZ)
- Demand-driven adjustment of suction power
- Filter status monitoring
- Volume flow rate or pressure control
- Timer-controlled switching system
- Access control
- System messages and event history
- Service menu

2 Status indications

Light blue:

- Standby mode

Green:

- Normal operation

Orange:

- Warnings
- Particulate filter nearly saturated

Red:

- Malfunction due to error condition
- Particulate filter saturated

Further information about ULT ProSight can be found here:



German: <https://www.ult.de/ia/prosight>

English: <https://www.ult-airtec.com/ife/prosight>



Figure 2: Rear interfaces of the ULT ProSight control

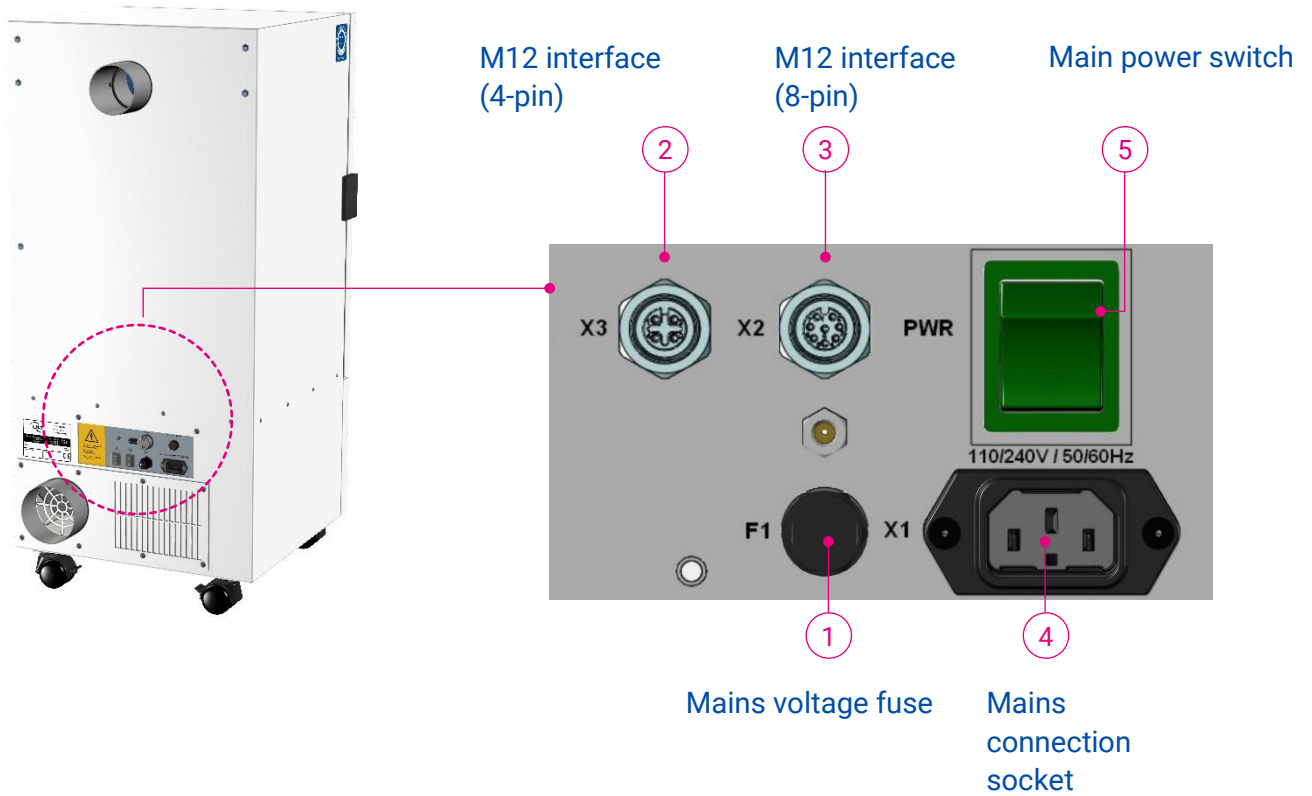

Description

1. Mains voltage fuse (10.0 A)
2. M12 interface "Remote Analog" (4-pin)
 - Remote ON/OFF and adjustment of suction power 0-10 V
3. M12 interface "Remote Digital" (8-pin)
 - System messages, filter messages, and remote ON/OFF
4. Connection for the mains power supply
5. Main power switch



Figure 3: Front operating panel Potentiometer control with LED status indicator

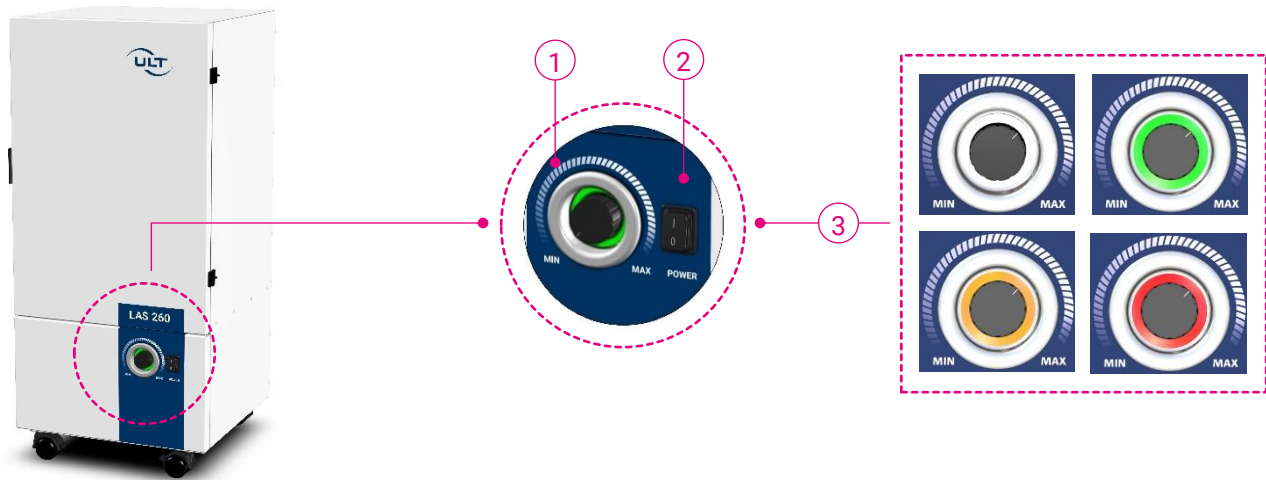

① Potentiometer

Selectable assignments:

- Direct control of the blower speed: freely set a fixed operating point within the limits of the maximum blower performance
- ecoflow CS[®]: Automatic compensation for increased filter saturation and varying numbers of collection spots

② ON/OFF switch

③ LED status ring

- Operating status indicators:
 - Standby mode via remote control (white)
 - Operation with no problems and notifications (green)
 - Warnings (orange)
 - Malfunction due to error condition (red)
- Particulate filter saturation indicator:
 - Particulate filter nearly saturated (orange)
 - Particulate filter saturated (red)



Figure 4: Rear interfaces – potentiometer control

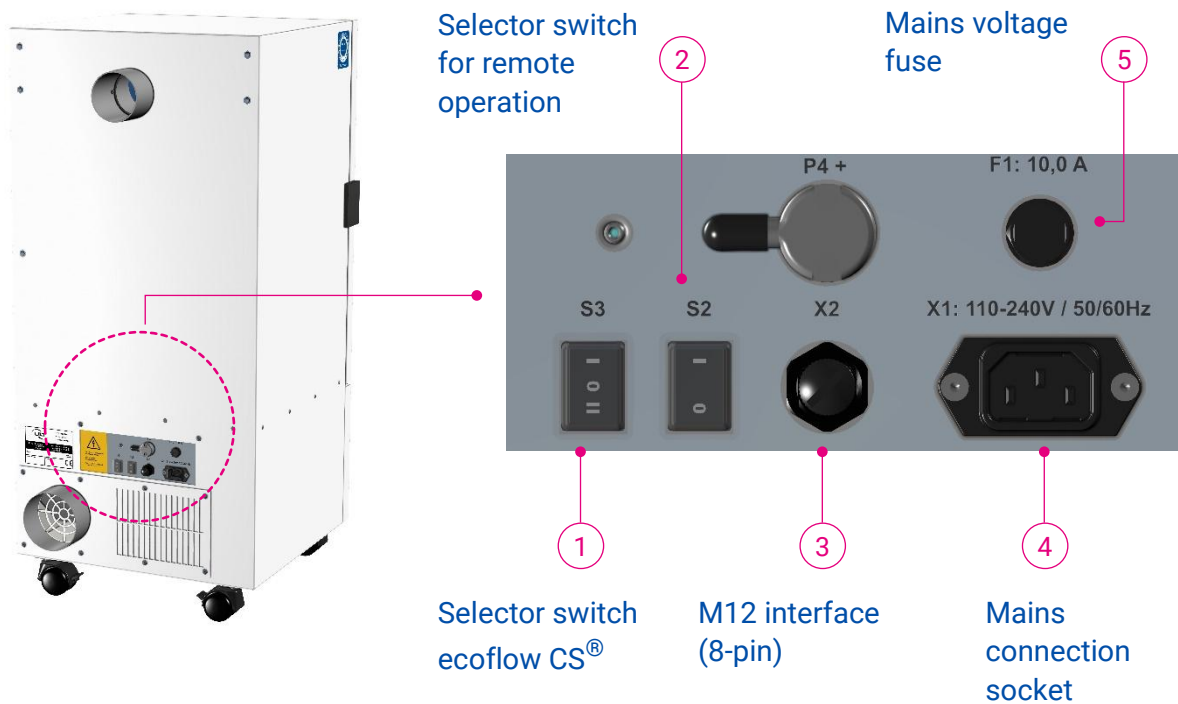

Description

1. ecoflow CS® switch and direct control
2. Bridge switch for remote ON/OFF
3. M12 interface
 - System messages, filter messages, and remote ON/OFF
4. Connection for the mains power supply
 - MD.20 110-240 V
 - MD.14 230 V
5. Mains voltage fuse (10.0 A)



Technical Data – LAS 260.1

Table 1: Technical Data – LAS 260.1

PARAMETER	UNIT	MD.20		MD.14
Max. volumetric flow rate	m ³ /h	360		635
Max. vacuum	Pa	9,500		3.200
Rated volumetric flow rate (fan characteristic curve)	m ³ /h @ Pa	100 @ 7,600 200 @ 5,000		200 @ 2 500
Protection class	IP	52		
Noise level (@ 50% - 100% volumetric flow rate)	dB(A)	47 - 60		45 - 50
Vacuum generator type		EC blower		
Rated voltage	VAC	1~110 ... 240		1~ 230
Rated frequency	Hz	50/60		
Voltage level		120 V	230 V	230 V
Rated motor power	kW	0.75	0.75	0,36
Rated current	A	9.2	5.3	2,2
Dimensions (width x depth x height)	mm	440 x 508 x 958		
Weight (without filter)	kg	Approx. 29.5		Approx. 30.4
Max. weight with filter	kg	Approx. 56.5		Approx. 57.4
Air intake versions:	nozzle	1x Ø 80 mm on rear		
	Connection options	Hose connection or optional arm mounting with bracket		
Air Outlet:		Outlet grille / outlet nozzle Ø 100 mm Both included with the unit (outlet nozzle pre-assembled)		
	Position	Rear of unit at bottom		
Mains cable EU (CEE 7/7)	m	3.0 (country-specific versions can be selected)		



Characteristic Curves and Operating Modes

Figure 5: Characteristic Curves and Operating Modes MD.20 (230 V)

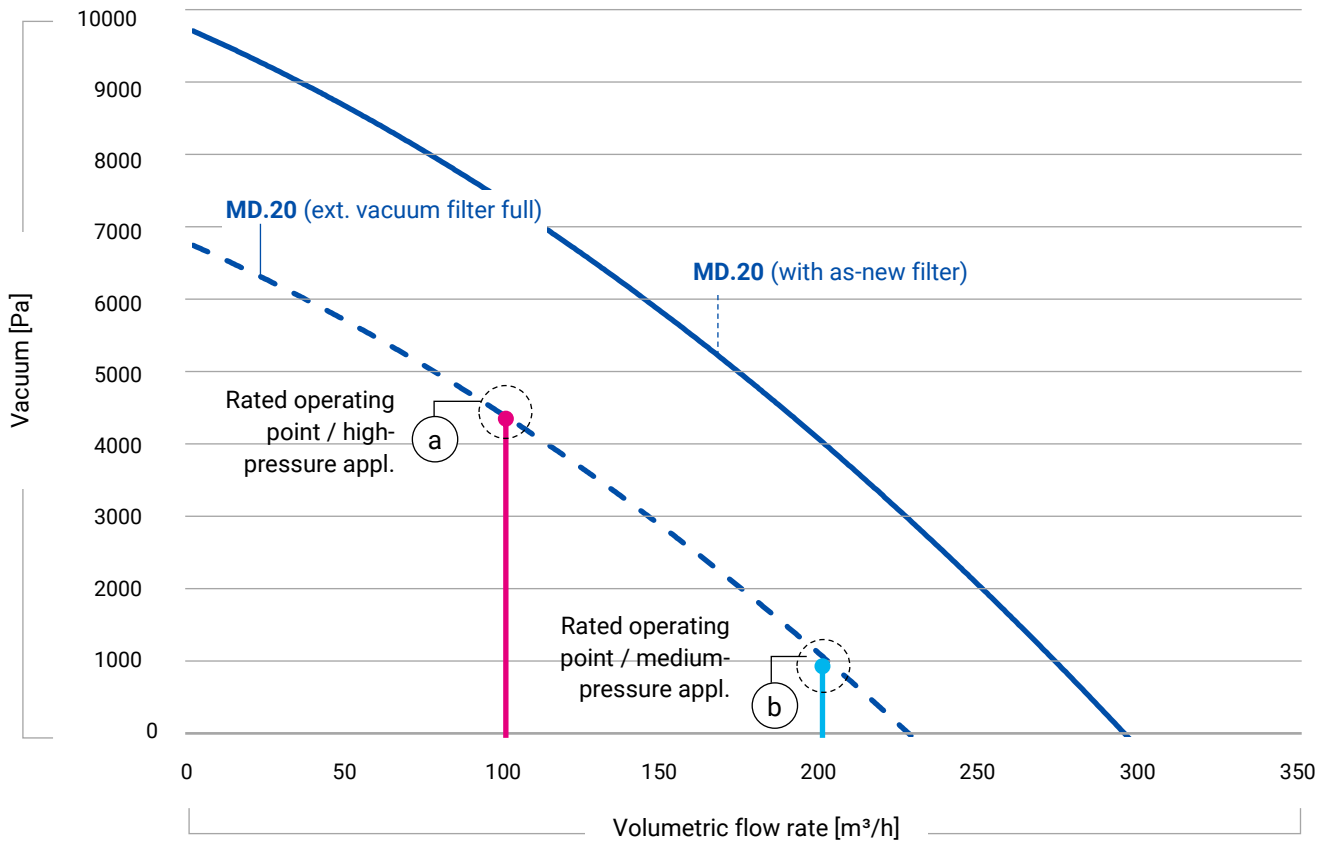
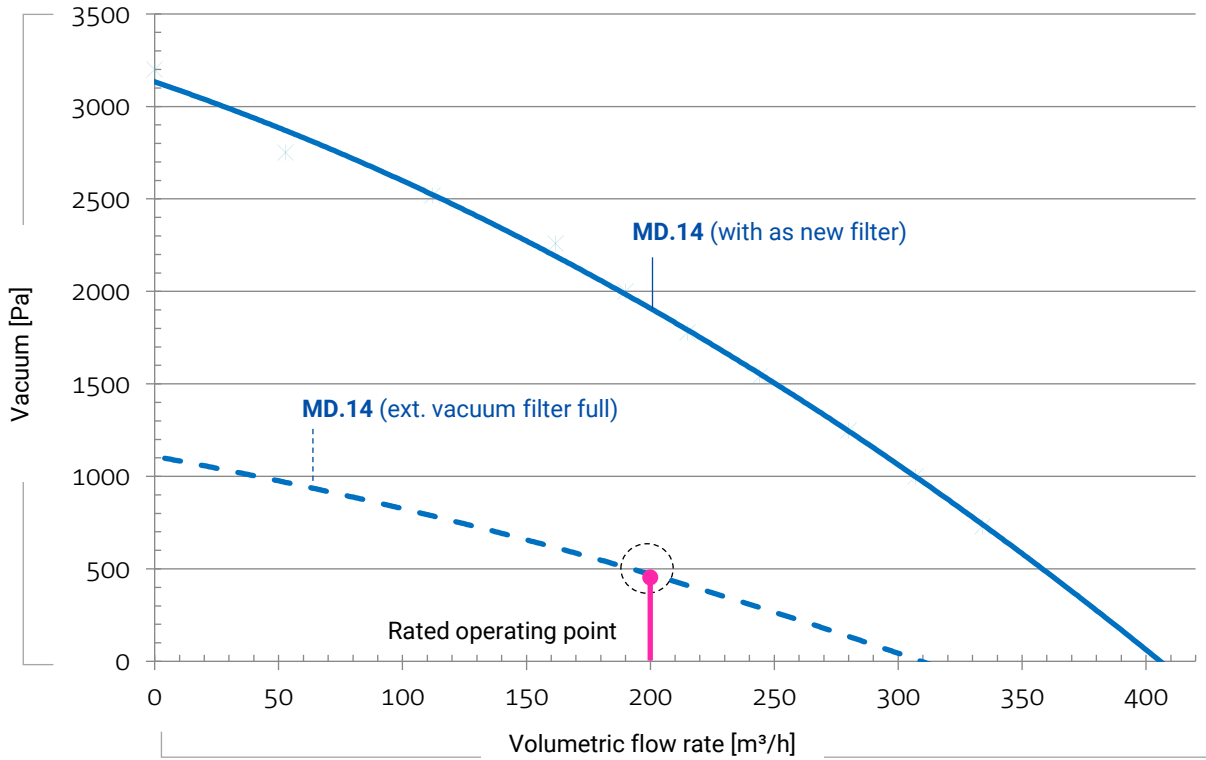



Figure 6: Characteristic Curves MD.14





LAS Series – Laser Smoke

Areas of Application

Laser cutting | laser marking | laser structuring | laser engraving

Operating Principle

On the clean gas side of the filter, an EC blower with a high pressure reserve generates a volumetric flow rate that is matched to the target application. The volumetric flow rate can be individually regulated to a freely adjustable setting. The raw gas containing pollutants or harmful substances is thus reliably extracted.

Laser smoke is produced in a wide range of different work processes in which lasers are used. This toxic, corrosive mixture of aerosol, gas, and nanoparticles represents a health hazard and has a negative impact on the quality of products and the machining process. Depending on the particular machining process, the resulting mixtures of substances that are produced and need to be removed from the raw gas can differ greatly.

The **particles** are separated out in a multi-stage storage filtration system and retained.

Finest suspended solids are retained by the HEPA H14 filter of the combined filter cassette H14A. This guarantees a particle separation rate of 99.995%.

The separation (adsorption) of air impurities in the form of **gas or vapor** takes place in the activated carbon fill of the combined filter cassette H14A.

The filtration effect of the activated carbon is based on adsorption, i.e. the process by which (gaseous) substances adhere to the surface of the activated carbon. In general, physical adsorption does not involve any chemical changes to the substance being adsorbed. The design of the filter is based on the rated volumetric flow rate of the units, while the contact time is designed for medium adsorption behavior.

Thanks to the high degree of purification, the **filtered clean gas** can be directed back to the working space (recirculated air mode). As a result there are no thermal losses.

Recirculated air mode is not permitted when the equipment is used to extract substances that are carcinogenic, mutagenic, or toxic for reproduction, unless this is permitted by the applicable regional regulations. In these cases the outlet nozzle included with the unit should be mounted on the outlet side. The filtered clean gas must be directed via a connected pipe section into a central air outlet system.

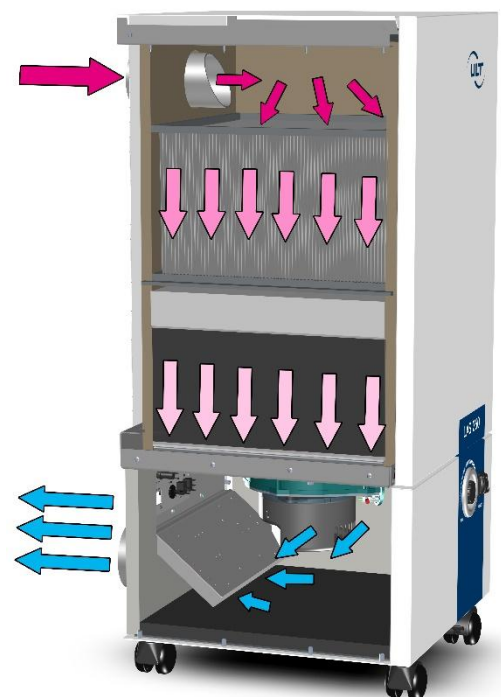

● Raw gas ● Filtration ● Clean gas



For use of the LAS 260.1 in recirculation mode when extracting fumes generated during the processing of high-alloy steels, the unit must be W3-certified under the German regulation TRGS 528 (welding-related work) in accordance with DIN EN ISO 21904-1/-2. Due to technical difficulties at the accredited authorities, there is currently no accredited testing institute available for units up to 400 m³/h (as of 03/2026).

To prepare for the W3 test, a real-world test with welding fumes was carried out with the LAS 260.1 at ILK Dresden in May 2025, following DIN EN ISO 21904-2:2020-06, prior to an accredited test. A separation efficiency of over 99% was achieved, qualifying the unit for use as a W3 filter. The results show that the standard filter configuration, with the H14A combination filter cassette as the main filter, clearly exceeds the required separation performance, with a measured result of over 99.9%.

Device Variant

A reliable filter combination is available for the extraction and filtration of harmful gas/dust mixtures from laser machining processes. For competent advice and help choosing the right filter combination, please contact your local dealer or get in touch with ULT AG directly via ult@ult.de.

The units in the LAS 260.1 series are equipped with the following filter configuration based on the individual requirements:

LAS 260.1 FK

A pre-filter cassette retains particles and prevents premature saturation of the downstream H14 main filter element. This multi-stage filter configuration is particularly well suited to the separation of dry laser smoke.

Table 2: LAS 260.1 FK

Filter configuration for laser smoke:	
Pre-filter cassette	
(1)	Raw gas intake
(2)	Particulate filter F, fine dust filter
	Filter class: ISO ePM ₁ 80% in acc. with ISO 16890
Combined filter cassette H14A	
(3)	Particulate filter H14
	Filter class: H14 HEPA filter, particulate air filter in acc. with EN 1822
(4)	Adsorption filter A10
	Filter medium: Activated carbon fill, 10 kg

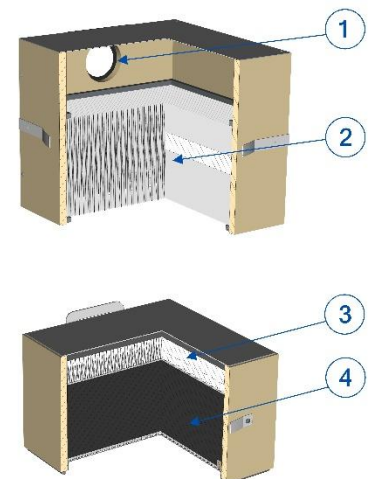



Accessory items

DN50 extraction system

Hoses



Flexible extraction hose DN 50, 2m	Antistatic, incl. 90° bend, socket and worm drive hose clips	3-00485
Flexible extraction hose DN 50, 3m	Antistatic, incl. 90° bend, socket and worm drive hose clips	3-00486
Flexible extraction hose DN 50, 5m	Antistatic, incl. 90° bend. socket and worm drive hose clips	3-00487
Flexible extraction hose DN 50, per meter	Antistatic, without accessories	6-06872

Hose accessories



Reducer DN 80 – DN 50	for device nozzle DN80	3-01294
Reducer DN 80 – 2x DN 50	Incl. 90° bend and socket	3-01319
Bend 90° DN 50	Antistatic, incl. worm drive hose clamp	3-00494
Socket DN 50	Antistatic, incl. worm drive hose clamp	3-00495
Y-piece DN 50 - 2*DN 50	Antistatic	6-06970

Extraction arm mounting elements



Table bracket black	Alsident System 50, accessory	2-5010-050
Device mounting console 2 x S50 extraction arm	incl. mounting material and connector hose	3-01283

Extraction arms



Alsident system 50, antistatic extraction arm	945 mm for table/device mounting	50-4737-1-6
---	----------------------------------	-------------

Collecting elements



Flat screen antistatic	Alsident System 50, accessory	1-503324-6
Round hood aluminium antistatic	Alsident System 50, accessory	1-5024-6
Extractor tube antistatic	Alsident System 50, accessory	1-5021-6
Suction gap antistatic	Alsident System 50, accessory	1-5020-6



DN80 extraction system

Hoses



Flexible extraction hose DN 80, 2m	Antistatic, incl. 90° bend, socket and worm drive hose clips	3-00489
Flexible extraction hose DN 80, 3m	Antistatic, incl. 90° bend, socket and worm drive hose clips	3-00490
Flexible extraction hose DN 80, 5m	Antistatic, incl. 90° bend, socket and worm drive hose clips	3-00491
Flexible extraction hose DN 80, per meter	Antistatic, without accessories	6-06874

Hose accessories



Bend 90° DN 80	Antistatic, incl. worm drive hose clip	3-00496
----------------	--	---------



Socket DN 80	Antistatic, incl. worm drive hose clip	3-00497
--------------	--	---------



Reducer DN 80 - DN 75	Antistatic, for connecting a DN80 hose to the System 75 extraction arm, incl. worm drive hose clip	3-00499
-----------------------	--	---------

Extraction arm mounting elements



Table bracket white	Alsident System 75, accessory	2-7510
---------------------	-------------------------------	--------

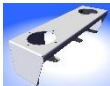

Device mounting console 1x S75 extraction arm	incl. mounting material and connector hose	3-01280
---	--	---------

Extraction arms



Alsident System 75, extraction arm	1290mm for table/device mounting	75-6555-1-5
------------------------------------	----------------------------------	-------------

Collecting elements



Flat screen	Alsident System 75, accessory	1-753324-5
-------------	-------------------------------	------------



Round hood aluminium	Alsident System 75, accessory	1-7524-5
----------------------	-------------------------------	----------



Extractor tube	Alsident System 75, accessory	1-7525
----------------	-------------------------------	--------



DN100 exhaust air system

Hoses and hose accessories



Flexible extraction hose DN 100, per meter	Antistatic, without accessories	6-06875
Socket DN 100	Antistatic, incl. worm drive hose clip	3-00500

Interface accessories

M12 interface accessories



M12 connection cable (8Pin)	incl. M12 Male adapter, length 3m	3-00234
M12 On/Off foot switch (8Pin)	incl. M12 Male adapter, length 3m	3-00235
M12 connection cable (4Pin)	incl. M12 Male adapter, length 3m	3-01560

Device power cables – supplied free of charge with ordered device



Swiss device power cable	Length 3.00 m	6-06056
UK device power cable	Length 2.00 m	6-06063
USA device power cable	Length 2.00 m	6-06091
EU device power cable (CEE 7/7)	Length 3.00 m	6-05990

Spark pre-separator*



Spark pre-separator NT092	For device mounting, incl. mounting material and connector hose	3-01281
---------------------------	---	---------

Secondary filter U15

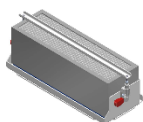

LAS 260.1 secondary filter module U15	Retrofit kit for exhaust air filtration	3-01277
Particle filter U15	For secondary filter	6-11662

* only for variant MD.20



Replacement filter

1-00221 LAS 260.1 MD.20 FK ProSight



Particle filter cassette F9

4-00107



Combined filter cassette H14A with sensor connector
For devices with ULT ProSight control

4-01011

1-00192 LAS 260.1 MD.20 FK

1-00208 LAS 260.1 MD.14 FK



Particle filter cassette F9

4-00107



Combined filter cassette H14A
For devices without ULT ProSight control

4-00109



Technical Illustration

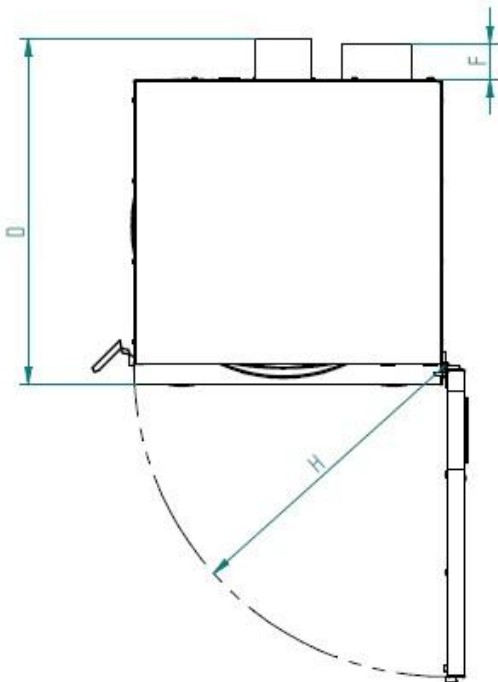
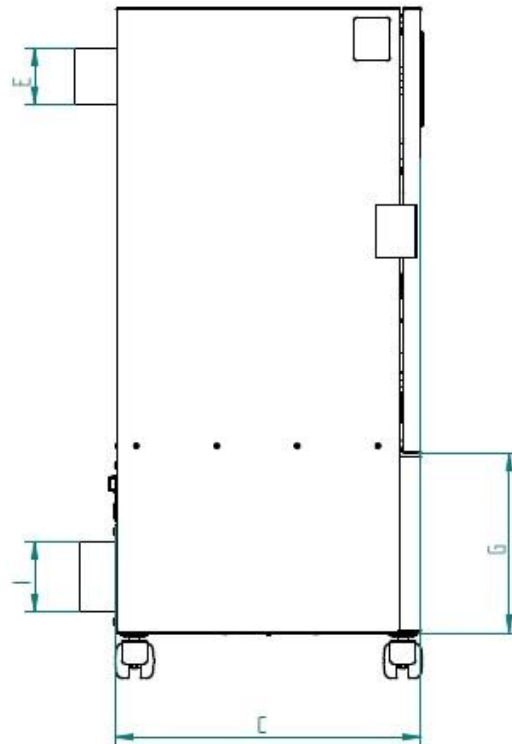
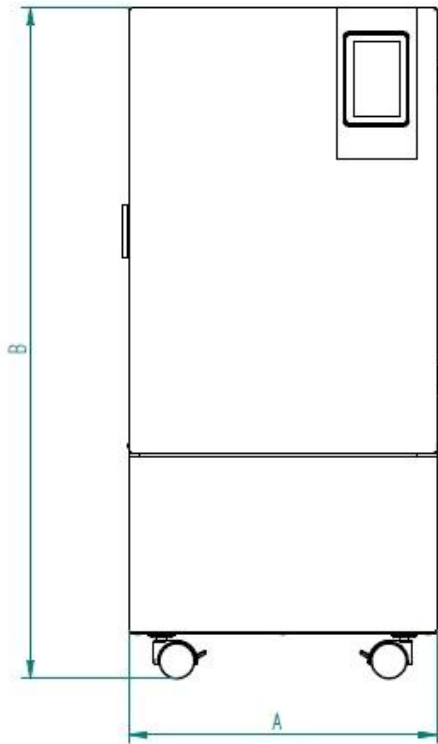

Dimensions (mm)	
A	440
B	960
C	435
D	495
E	80
F	50
G	255
H	445
I	100





ULT AG

Am Göpelteich 1
02708 Löbau
Germany

Phone: +49 3585 4128-0
Fax: +49 3585 4128-11
E-mail: ult@ult.de
Website: www.ult.de



air quality