

Operating Instructions

LAS 260.1 Extraction and Filtration Unit



Valid for variants:

1-00192, 1-00206

LAS 260.1 MD.20 FK

Date 08/2024

ULT AG
Am Göpelteich 1
02708 Löbau, Germany
Phone: +49 3585 4128-0
Fax: +49 3585 4128-11

Contents

Introduction	5
General information	5
Intended use	5
Safety	6
Symbols	6
General safety instructions	7
Obligations of the operating company	8
Obligations of personnel	8
Safety instructions for fire hazards	9
Occupational safety	10
Residual hazards	12
Type plate	13
Disposal information	13
Technical Overview	14
Technical Illustration	15
Technical Data	17
Function and operation	19
Device variant and application	20
Transport and storage	21
Installation	21
Installation and connection of the unit	21
Moving the unit	22
Connections and operating controls on the rear	22
Interfaces	22
Electrical connection	23
M12 interface	23
Commissioning	24
Operation	24
LED status ring	25
Operating modes	26
Shutdown	29
Maintenance and servicing	30
General maintenance and servicing instructions	30



Filter change	31
Replacement of the pre-filter stage	32
Replacement of the main filter	35
Filter installation	35
Optional outlet nozzle	38
LED status messages	39
Status white	39
Status green	39
Status orange	40
Status red	41
Potential malfunctions	42
Replacement and wear parts	43
Filter list	44
Service	45

Attachments:

- EU Declaration of Conformity
- Interface diagram
- Confirmation of initial electrical type testing in accordance with DGUV

Introduction

General information

This document must not be reproduced, duplicated, or distributed without written permission from the manufacturer. The product to which these operating instructions belong is suitable only for the purpose specified in the section on intended use in this document and must only be operated in accordance with the instructions set out below.

ULT AG cannot be held liable for damage to people, animals, machinery, the environment, or property or for other financial losses caused by improper installation, repairs, or maintenance or by improper use of the equipment. All forms of usage not stated in these operating instructions are deemed to be improper and are therefore prohibited. This document serves for information purposes only and does not represent a contract.

As part of product improvements and product modifications, ULT AG reserves the right to change the specifications of the product and the corresponding documentation at any time without prior notice. This does not result in an obligation to update previous documents.

Intended use

The intended use is defined in the following section: “Device variant and application”.

The LAS 260.1 must not be used for any other purposes without approval from the manufacturer. Unauthorized conversion or modifications to the LAS 260.1 are prohibited for safety reasons.

The LAS 260.1 is used for extraction and filtration of dry and non-combustible dusts and gases in air mixtures that are not potentially explosive and are produced during laser machining processes.

The intended use also includes compliance with the instructions provided by the manufacturer in relation to commissioning, operation, and maintenance.

Use for any purpose above or beyond these definitions is deemed to be improper use. No liability is accepted for damages resulting from this.

NOTICE

The supplied Extraction and Filtration Unit LAS 260.1 will only work correctly with the matching filtration system that is designed for use with the equipment type. Operation with other filtration systems than the one supplied is deemed to be improper use.



Safety

The LAS 260.1 has been built in accordance with the state of the art and is safe to operate. Nonetheless, the device can still present potential hazards if it is used by untrained personnel improperly or for purposes for which it is not designed.

During the development and manufacture of the LAS 260.1, every step has been taken to ensure compliance with the safety requirements of the directives and standards listed in the EU Declaration of Conformity.

The information provided in this manual should never be given a higher priority than the individual responsibility of persons working on/with the machine and/or the local regulations that apply.

During operation and during all other work on the LAS 260.1, the operating company is responsible for the following in all cases:

- Safety of all persons involved;
- Safety of the device and all other parts of the equipment;
- Environmental protection.

Symbols

In this manual, all descriptions of actions to be carried out are supplemented with the necessary safety instructions.

Safety instructions will warn you about:

- Residual hazards that can occur unexpectedly.
- Residual hazards that can lead to serious injuries.



Indicates a hazardous situation with high risk that, if not avoided, will result in death or serious injury.



Indicates a hazardous situation with moderate risk that, if not avoided, could result in death or serious injury.



Indicates a hazardous situation with low risk that, if not avoided, could result in minor or moderate injury.



Indicates the risk of potential material damage without personal injury.

General safety instructions

 **DANGER**

The Extraction and Filtration Unit LAS 260.1 must only be used, serviced, and repaired by persons who are familiar with the unit and who have been instructed on potential hazards. These persons must also know the intended use and the operating instructions.

 **DANGER**

Explosion hazard

Do not use the equipment to extract explosive concentrations of gases, vapors, or dusts.

 **DANGER**

Health hazard

Do not use the equipment to extract substances that are carcinogenic, mutagenic, or toxic for reproduction and/or toxic gases, vapors, or dusts in recirculated air mode, unless this is permitted by the applicable regional regulations.



Otherwise the filtered clean gas must be carried away via a connected pipeline into an air outlet system.

 **CAUTION**

Risk of short circuit due to ingress of liquids

Do not use the equipment to extract liquids.

 **WARNING**

Fire hazard

Do not use the equipment to extract ignition sources.

Obligations of the operating company



The operating company agrees to only permit persons to work on the LAS 260.1 who:

- Are familiar with the legislation and requirements relating to occupational health & safety and accident prevention;
- Have read and understood the safety and warning signs and have confirmed this with their signature.

The safety awareness of staff must be checked at regular intervals.

The installation and operating instructions must be kept in a suitable place where they are protected against dust and moisture. The storage location must be easily accessible and clearly visible at all times for all users of the system.

Obligations of personnel



Persons tasked with work on the LAS 260.1 agree to read the safety instructions before starting work, and will confirm with their signature that they have understood them.

WARNING



Make sure that you never use any products that are damaged.

Read these operating instructions carefully before starting the installation and assembly work.

Always comply with the safety instructions provided.

Look out for safety symbols for mechanical hazards and electrical hazards (e.g. work on live components) on the LAS 260.1. These symbols tell you that there is an immediate, direct danger. If such dangers are not avoided, they can cause severe injuries or even death.

Live or moving components can cause severe or fatal injuries.

Installation, connection, commissioning, maintenance, and repairs must only be carried out by qualified personnel taking into account this manual and all other enclosed instructions relating to any accessories fitted; all such work must be performed in accordance with the applicable national/regional regulations (health & safety / accident prevention).

Safety instructions for fire hazards

 **DANGER**

The Extraction Unit LAS 260.1 is designed solely for the extraction of airborne dusts and gases produced during laser machining in non-flammable concentrations. The filtration system is designed for the separation of dusts and gases that are not potentially explosive. It is prohibited to use the equipment for the extraction of potentially explosive mixtures.

Before using the unit you must inform yourself about the flammability and/or explosiveness of the vapors, gases, and dusts that arise during processing. It is prohibited to use the equipment for the extraction of potentially explosive and flammable mixtures.

So that you can properly assess the explosion and fire hazard and define appropriate safety measures, please inform yourself about the key parameters of your dust that are relevant in terms of technical safety.

To avoid the risk of fire and explosion, the system must never be used to extract e.g. hot, glowing, smoldering parts, glowing ashes/shavings/filings, or smoldering cigarettes.

If the Extraction and Filtration System is used improperly, the risk of a fire hazard cannot be ruled out, so it is recommended that a fire extinguisher is provided in the immediate vicinity or that an extinguishing system is installed.

Fire extinguishers with suitable extinguishing agents should be chosen based on the reactive properties of the substances sucked into the overall system.

In the event of fire:

1. Immediately switch off the unit.
2. If possible, close the inlet opening to prevent the supply of oxygen.
3. If possible, close the outlet openings.
4. Bring the fire extinguisher into position and spray extinguishing agent through the intake opening.
5. Do not open any other parts of the enclosure.

 **DANGER**

Please note that the filter materials themselves are also flammable, and that toxic gases and vapors can be released when they burn.



Occupational safety



Before installing the unit and taking it into operation, make sure that you read and carefully follow the operating instructions, in particular the safety instructions.

The user must be given instructions and trained by an authorized person during initial commissioning. Personnel must be informed about all instructions relating to occupational safety, about prohibited methods of operating the unit, and about potential hazards.

The machine must only be operated, serviced, and repaired by authorized, trained, and instructed personnel who satisfy the legal minimum age requirements.

All work on electrical and mechanical components in the machine must only be carried out by instructed personnel or by persons working under the guidance and supervision of an instructed skilled person in accordance with the applicable regulations and standards of electrical and mechanical engineering. Here, a “skilled person” is someone who, based on their professional training, knowledge, and experience as well as their knowledge of the relevant standards and regulations, is able to assess the work assigned to them and identify potential hazards.



- Always disconnect the mains plug after use, before cleaning or maintenance of the LAS 260.1, and before replacing any parts.
- Saturated filter materials must always be disposed of in accordance with the applicable waste regulations.
- Always use genuine replacement parts and wear parts from ULT AG.
- Improper interventions or tampering pose a significant safety risk.
- Never use jet washing equipment to clean the LAS 260.1.
- Safety devices that are designed to prevent or eliminate hazards must be regularly serviced and must be tested at least once a year to make sure that the required safety functions work properly.
- It must be ensured that the mains connection cable cannot be damaged due to heat, oil, by equipment running over it, or by pulling, straining, or similar.
- The mains connection cable should be regularly inspected for signs of damage.

- Do not use the LAS 260.1 if the mains connection cable is not in perfect working order. Always use a genuine replacement part when replacing the mains connection cable.
- During commissioning, make sure that no foreign objects (cleaning cloths, tools, or similar) can be sucked in.
- Refrain from all methods of working that might impair or endanger the safety of personnel, the unit, or the working area and its surroundings.
- The operator is obliged to immediately report any safety-related changes occurring on the unit.
- Observe all attached information signs and warnings.
- In the event of extended or permanent work interruptions, switch off the unit and disconnect it from the mains power supply.
- In the event of danger, switch off the unit immediately.

NOTICE

The unit must be connected to an AC mains network that is protected with a circuit breaker or fuse (connected loads: see “Technical Data” on page 17).



Residual hazards



Hazard prevention – mechanical systems

All moving parts (fan, motor) are protected with fixed and securely mounted guards that can only be removed with tools.

RESIDUAL RISK:

- Severe injuries can be caused if a fixed, securely mounted guard or trim panel is removed with tools while the unit is running.
- Opening or closing the door catch on the filter door can result in crush injuries or other types of injury. The door catch must be treated with the appropriate care.

Hazard prevention – electrical systems

All live parts of the LAS 260.1 are insulated to protect against contact or are protected with fixed and securely mounted guards that can only be removed with tools.

The system corresponds to protection class I in accordance with EN 60335.

RESIDUAL RISK:

- Severe injuries due to electric shock can be caused if a fixed, securely mounted guard or trim panel is removed with tools without first disconnecting the mains connection cable.

Hazard prevention – harmful substances

Only filters that are suitable for the type of unit are permitted to be used. Do not operate the unit without a filter, or with a filter that is defective.

RESIDUAL RISK:

- The use of defective or unsuitable filters poses health hazards.

Hazard prevention – disposal



The LAS 260.1, the filter elements, and other accessory parts must be disposed of in accordance with the applicable rules and regulations at the end of their service life.

RESIDUAL RISK:

- If the equipment is not disposed of properly, this can cause health hazards and can pollute the environment.

Type plate

The type plate is part of the device and must never be removed. Information about the type and the connected electric load depends on the particular unit and can be found in the section “Technical Data” on page 17.

		air quality	
ULT AG Am Göpelteich 1 02708 Löbau Germany		T +49 3585 4128-0 E ult@ult.de www.ult.de	
Extraction and filtration device, Type LAS 260.1 MD.20 FK			Made in Germany
Year - Device No. JJJJ 14 xxxx	Connected load 110-240 V 50/60Hz 10 A		

Disposal information

The products of ULT AG are intended solely for commercial use. In accordance with the requirements of the EU directive (WEEE Directive 2012/19/EU) and of the German Electrical and Electronic Equipment Act (ElektroG), ULT AG is licensed in Germany by Stiftung Elektro-Altgeräte-Register (EAR) as a manufacturer under the WEEE registration number DE 42863881. We accept no duty of disposal for end-of-life equipment from non-private users after the end of use. For information about the rules and regulations for registration and disposal outside of Germany, please contact your dealer or importer.

On request, ULT AG can offer the disposal of end-of-life units as a service in Germany.



Technical Overview

Overall system



1	Intake nozzle
2	Filter chamber door
3	Clean gas outlet
4	Casters
5	Connections on the rear
6	Front operating panel

Technical Illustration Dimensions

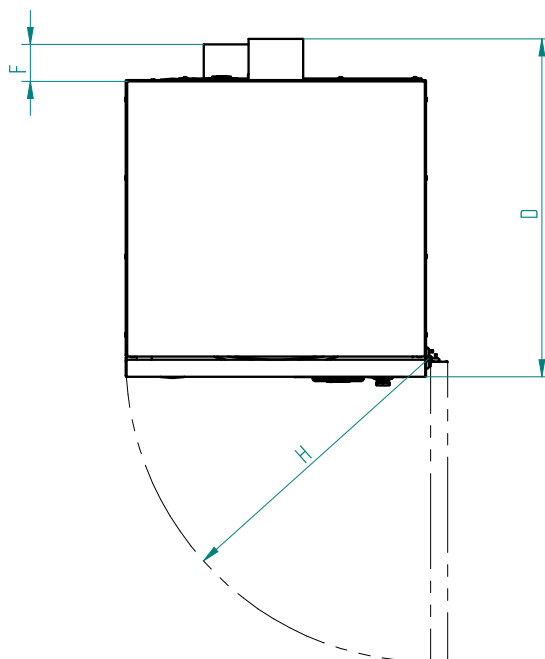
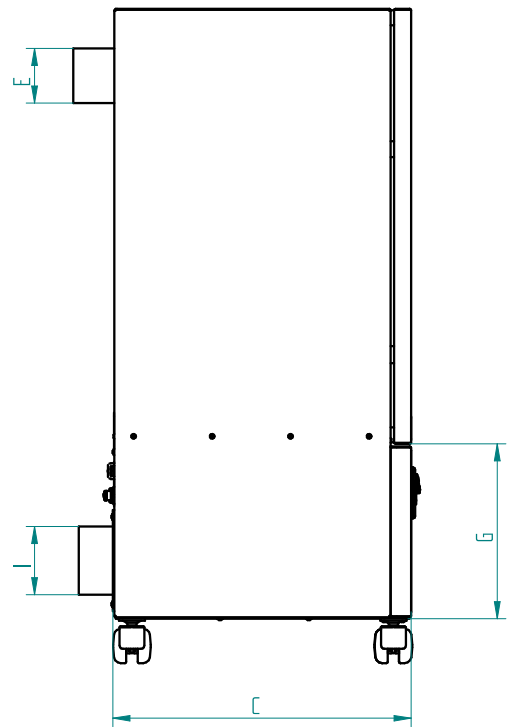
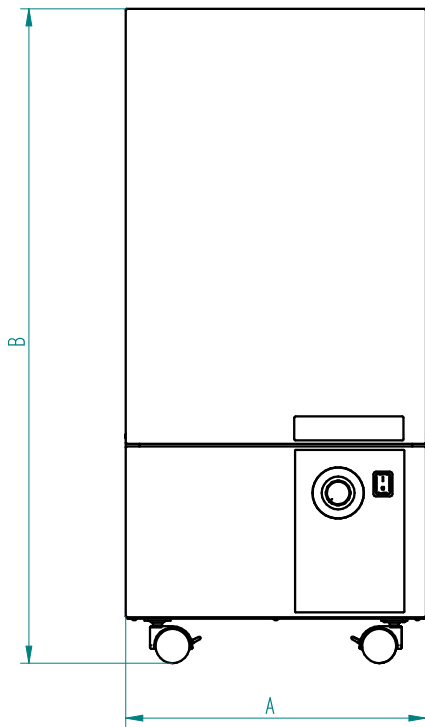

Dimensions		
	(mm)	(inch)
A	440	17.32
B	960	37.79
C	435	17.12
D	495	19.48
E	80	3.14
F	50	1.96
G	255	10.03
H	445	17.51
I	100	3.93

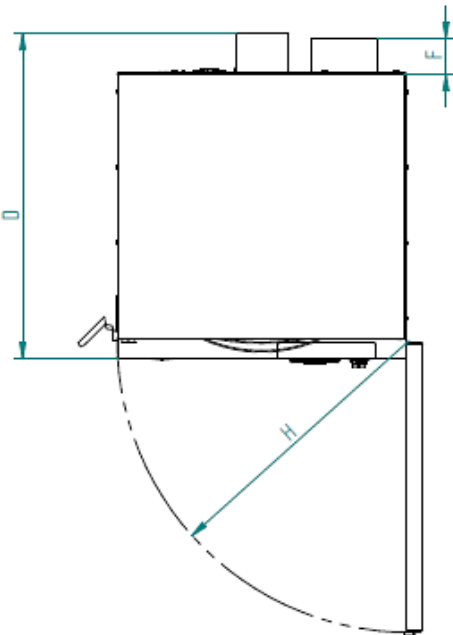
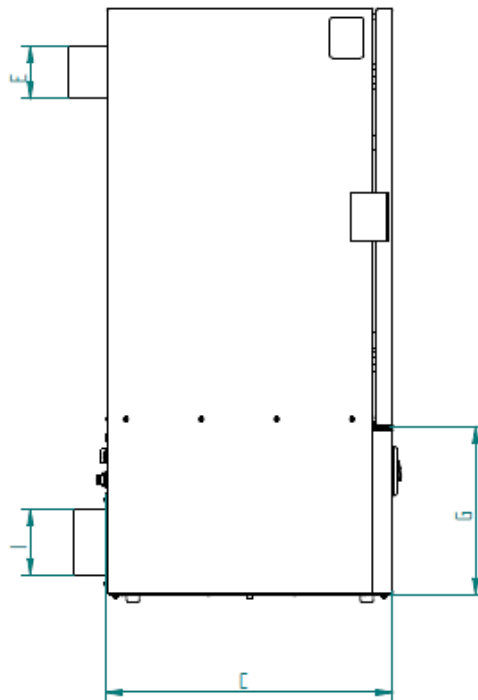
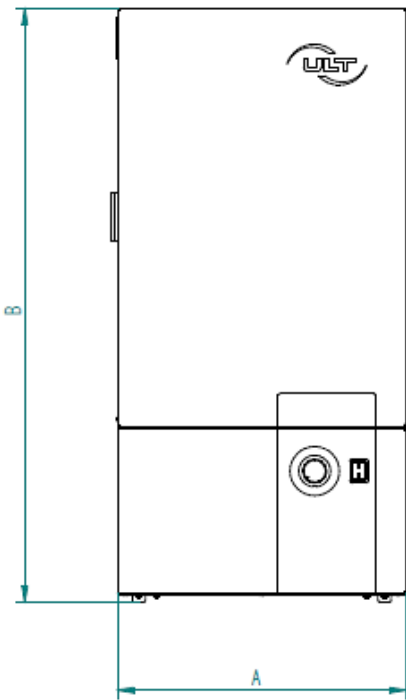

Dimensions		
	(mm)	(inch)
A	440	17.32
B	905	35.62
C	435	17.12
D	495	19.48
E	80	3.14
F	50	1.96
G	255	10.03
H	445	17.51
I	100	3.93

Technical Data

Dimensions

Width (A):	440 mm (17.32'')
Height (B):	960 mm (37.79'')
	905 mm (35.62'') with device foot)
Depth (C)	435 mm +60 mm with intake (17.12'') + 2.36'') with intake)
Weight (without filter):	Approx. 29.5 kg (65.03 lb)
Weight (with filter):	Approx. 56.5 kg (124.55 lb)

Temperatures

Ambient air during operation	Min. 10 °C, max. 35 °C (min. 50 °F, max 95 °F)
Transport and storage	Min. -25 °C, max. 70 °C (min. -13 °F, max 158 °F)
Sucked-in process air	≤ 55 °C (≤ 131°F)

Humidity

10% - 80% relative humidity (non-condensing)

Air intake

1x pipe nozzle, DN80, optionnel DN50

Air outlet

Outlet grille or outlet nozzle, DN100, on rear of unit

Performance data

MD.20

Max. volumetric flow rate:	360 m ³ /h (212cfm)
Max. vacuum:	9,500 Pa (38.17'')WC)
Rated volumetric flow rate:	100 m ³ /h @ 7,600 Pa (58.8cfm @ 30.54'')WC)
	200 m ³ /h @ 5,000 Pa (117.7cfm @ 20.09'')WC)
Noise level:	47 dB(A) - 60 dB(A)

Electrical connection

MD.20

Rated voltage:	110 V - 240 V
Rated frequency:	50/60 Hz
Rated current:	9.2 A (120 V) - 5.3 A (230 V)
Rated power consumption:	0.9 kW (120 V) - 0.8 kW (230 V)
Series fuse:	16 A



Energy consumption	W at potentiometer position (%): <ul style="list-style-type: none">○ 70 @ 0%○ 270 @ 25%○ 490 @ 50%○ 750 @ 75%○ 800 @ 100%
Degree of protection	IP52
Material	Enclosure: <ul style="list-style-type: none">○ Robust sheet steel enclosure○ Powder coated
Equipment	<ul style="list-style-type: none">- Freely adjustable volumetric flow rate control- Switchover: medium-pressure / high-pressure operation- Universal LED status ring for particulate filter saturation and device status- Outlet grille; air outlet flange collar DN100- ecoflow CS[®] (for maintaining constant vacuum)- M12 interface- Remote ON/OFF switch- Lockable casters
Included in the delivery	<ul style="list-style-type: none">- LAS 260.1 including filter cartridges- Mains cable- Operating instructions

Function and operation

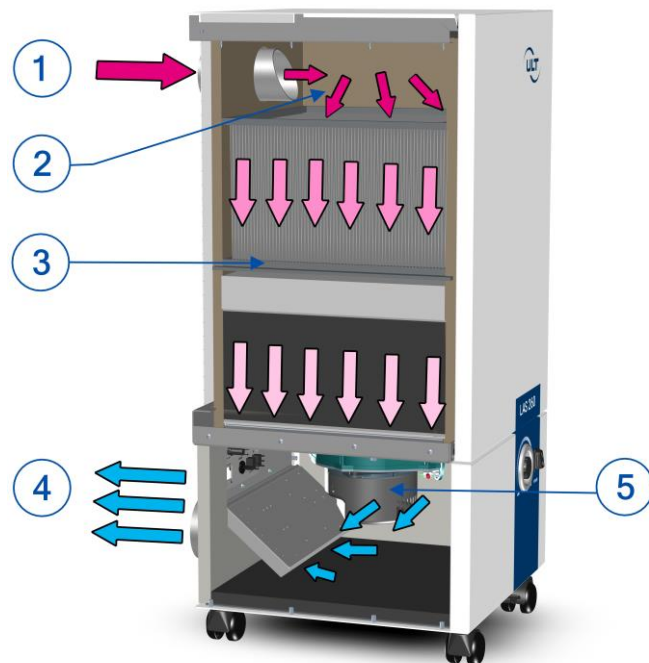

- | | |
|--------------------|--------------------|
| ① Intake nozzle | ④ Outlet grille |
| ② Air distribution | ⑤ Vacuum generator |
| ③ Filter | |

The blower installed in the LAS 260.1 generates a vacuum at the intake connector or at the relevant connected collection elements. As a result, impurities in the air can be collected and sucked out directly at the point of creation.

The contaminated air is guided through the filters in the LAS 260.1 and purified.

The purified air passes through an integrated muffler and comes out through the outlet grille on the rear of the unit. If recirculated air mode is not required, the outlet grille can simply be rotated to quickly and easily reconfigure the setup so that the outlet air is discharged rather than being fed back in. The filtered air is then directed into an air outlet system.

Device variant and application

Application LAS

The LAS 260.1 is used for extraction and filtration of dry and non-combustible dusts in air mixtures that are not potentially explosive and are produced during laser machining processes.

Areas of application:

- Laser cutting
- Laser engraving
- Laser structuring
- Laser sintering

The LAS 260.1 is to be used on laser workstations or laser machining stations in such a way that the hazardous substances that arise are extracted directly at the point where they are generated.

Filter FK

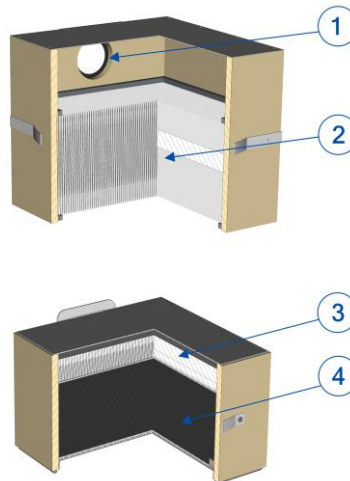

Pre-filter: Particulate filter cassette F9

- ① Raw gas intake
- ② Pleated filter F9
Filter class ISO ePM1 80% in acc. with ISO 16890

Main filter: Combined filter cassette H14A10

- ③ Pleated filter H14
Filter class HEPA H14 in acc. with EN 1822
- ④ Adsorption filter, activated carbon, 10 kg (22.04 lb)

Thanks to their depth effect, the pre-filters are particularly well suited to the separation of laser smoke. A large part of the particles in the laser smoke is adsorbed. Finest suspended solids are retained by the HEPA H14 filter of the combined filter cassette H14A10. This guarantees a particle separation rate of 99.995%. The activated carbon layer is used for filtration of gases, vapors, and odors.

Transport and storage

NOTICE

The LAS 260.1 is designed to be transported in a vertical position.

The following conditions must be met during transport and storage:

Temperature:	-25 °C to +55 °C (-13 °F to 131 °F)
Temporarily (max. 24 hrs):	Up to +70 °C (up to 158 °F)
Humidity:	10% - 80% relative humidity (non-condensing)

Installation

Installation and connection of the unit

NOTICE

Before starting with the installation:

- Check the unit and the filter for any transport damage that may be present.
- Report any damage to the carrier.
- Remove all transport packaging.
- All transport packaging is recyclable; please consult your local waste disposal company for information about proper disposal.

The Extraction Unit should be set up in the place intended for it. It should be on a level floor and standing upright, with horizontal surfaces properly leveled. Apply the brakes of the casters.

Minimum distances must be maintained to other machines or parts of the building to ensure that safe maintenance access is provided and to allow the clean gas to escape without any obstructions.

These are:

- On all sides: +0.5 m (19.68'')

Minimum distances for maintenance and service activities:

- On all sides: +1.0 m (39.37'')

The LAS 260.1 is operated standing up. You can use the intake nozzle depending on your usage requirements.

The intake nozzle of the Extraction and Filtration System LAS 260.1 is designed for the connection of:

- Hose systems 1 x DN80.

The hose system is to be mounted by the operator directly on the pipe nozzle during the course of the commissioning process.

CAUTION



Moving the unit

CAUTION

Before moving the unit to a new location, first switch it off and disconnect the mains plug.

The casters allow the unit to be easily moved without having to lift it. The device can be pushed or pulled to the required new location.

When moving the unit, do not pull or push the unit by the connected collection element.

The unit must only be moved with the casters on level surfaces. If it is moved with the casters on an inclined surface, there is a risk that control over the unit could be lost, resulting in personal injury or damage to the unit. Once you have finished moving the unit to its new location, apply the brakes on the casters again.

Connections and operating controls on the rear

Interfaces

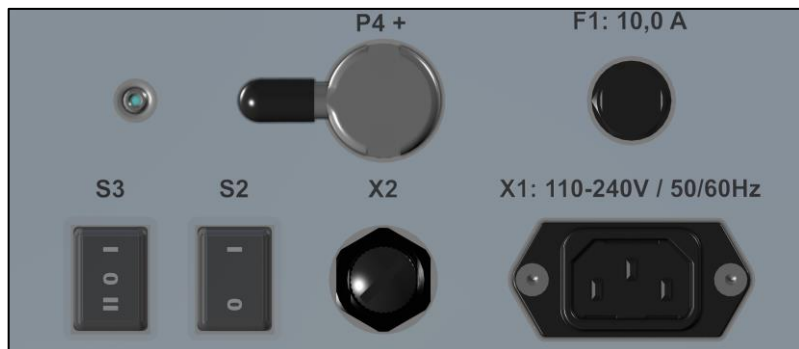

X1: Connection for the mains power supply

X2: M12 interface

S2: Bridge switch for remote ON/OFF

S3: ecoflow CS[®] switch and direct control

F1: Mains voltage fuse (10.0 A)

P4: Pressure measurement port for service work

Electrical connection

Use the supplied mains plug to connect the unit to the AC mains network 110 V ... 240 V / 50/60 Hz. The supply line must be protected with a fuse of at least 16 A.

Harmonic currents

The units in the LAS 260.1 series are professional units for use in commercial and industrial environments.

In accordance with EN 61000-3-2, approval is required from the responsible energy supply company (mains network operator) for connection to a public low-voltage network.

The unit can cause electromagnetic interference in nearby equipment or systems.

NOTICE

The interfaces are intended to be used solely during installation and disassembly of the system. They must not be disconnected while a load is applied and are not to be used as a mains disconnect device for the extraction unit.

NOTICE

The Extraction and Filtration Unit must only be operated using the supplied mains cable. Use of other mains cables may result in damage to the device.

M12 interface

As standard, the M12 interface provides the following functions: status message, filter warning, filter full, and remote ON/OFF. The LAS 260.1 can be controlled by a higher-level machine via this interface.

Please refer to the interface diagram for information about the assignments on the interface.

The status message is output via a potential-free contact operating as a normally open contact. This output signals that the system is operational. The status message indicates flow monitoring and does not signal the filter status.

The filter saturation levels are output via a potential-free contact operating as a normally closed contact. If the signal for a full filter is output then the filter is completely saturated. In this case, proceed in accordance with the maintenance instructions in the section "Maintenance and filter replacement."

The remote ON/OFF function is used to switch the unit on or off via a higher-level controller.

The time interval between switching on and switching off should be at least 5 minutes. Otherwise there is a risk that the blower might be damaged.

NOTICE



Commissioning

Unpack the LAS 260.1 and set up the unit.

- Open the door catches on the sidewall of the enclosure and open the filter chamber door.



- Check that the filter cassettes are securely mounted.
- Close the filter chamber door again.
- Connect the hose.
- Connect the mains supply cable.

 **DANGER**

Never operate the unit without a filter.

Operation

Switch on the LAS 260.1 via the ON/OFF switch ① on the front of the unit. Before taking the unit into operation, check that the suction connection is properly connected and the air outlet on the rear of the unit is free of any obstructions.

The LED status ring ② indicates the status of the unit and the condition of the particulate filters.

With the aid of the potentiometer ③ the suction power of the unit can be adjusted to suit the application requirements.

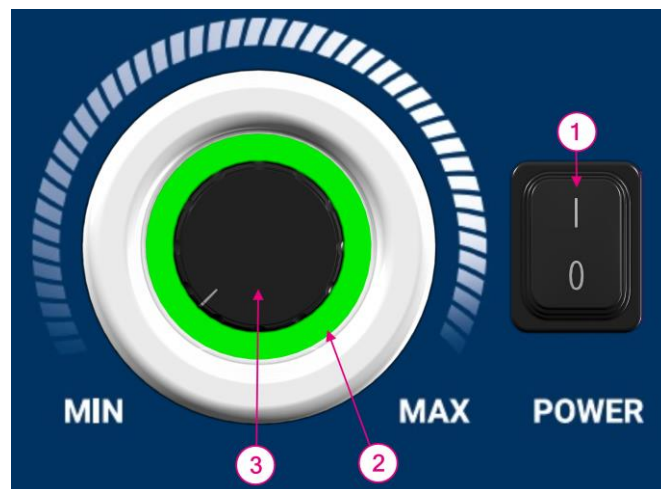

NOTICE

During initial commissioning, set the suction power to 100% at the potentiometer, fully open all intake openings, and run the unit for approx. 2 minutes.

If the LED status ring flashes **red** after initial commissioning, then you should check whether the filter is correctly seated.

Afterwards you can carry on working normally with individual suction power settings.

LED status ring

The LED status ring indicates the status of the unit and the condition of the particulate filters.

A detailed listing of the possible signaling states can be found in the section “LED status messages.”

Color code	Description
<p>White</p> 	<p>Standby mode (only applies during remote operation)</p>
<p>Green</p> 	<p>No errors Notifications</p>
<p>Orange</p> 	<p>Warnings</p>
<p>Red</p> 	<p>Critical messages</p>



Operating modes

The Extraction and Filtration System LAS 260.1 can be operated in standard operating mode or in remote operation (connection of a higher-level machine to the M12 interface).

Standard operating mode

In standard operating mode, operation of the Extraction and Filtration System LAS 260.1 takes place solely via the operating controls on the front and rear of the machine.

NOTICE

Prerequisite for standard operating mode:

- Switch **S2** in position "1"

The suction power can be individually adjusted via the potentiometer on the front of the unit.

Clockwise rotation allows you to continuously increase the suction power, while counter-clockwise rotation continuously reduces the suction power.

Control range of the potentiometer in standard operating mode:

- In standard operating mode the rotational speed of the blower can freely adjusted up to the maximum rotational speed.

ecoflow CS[®]

The LAS 260.1 has one switchable ecoflow CS[®] controller (S3 switch) for demand-driven adjustment of the suction power in medium-pressure and high-pressure operation.

Increased filter saturation and varying numbers of collection points during ongoing operation (e.g. open or closed extraction arms) are automatically compensated for by increasing or reducing the blower speed.

Characteristic curves and operating modes (Characteristic curves for 230 V)

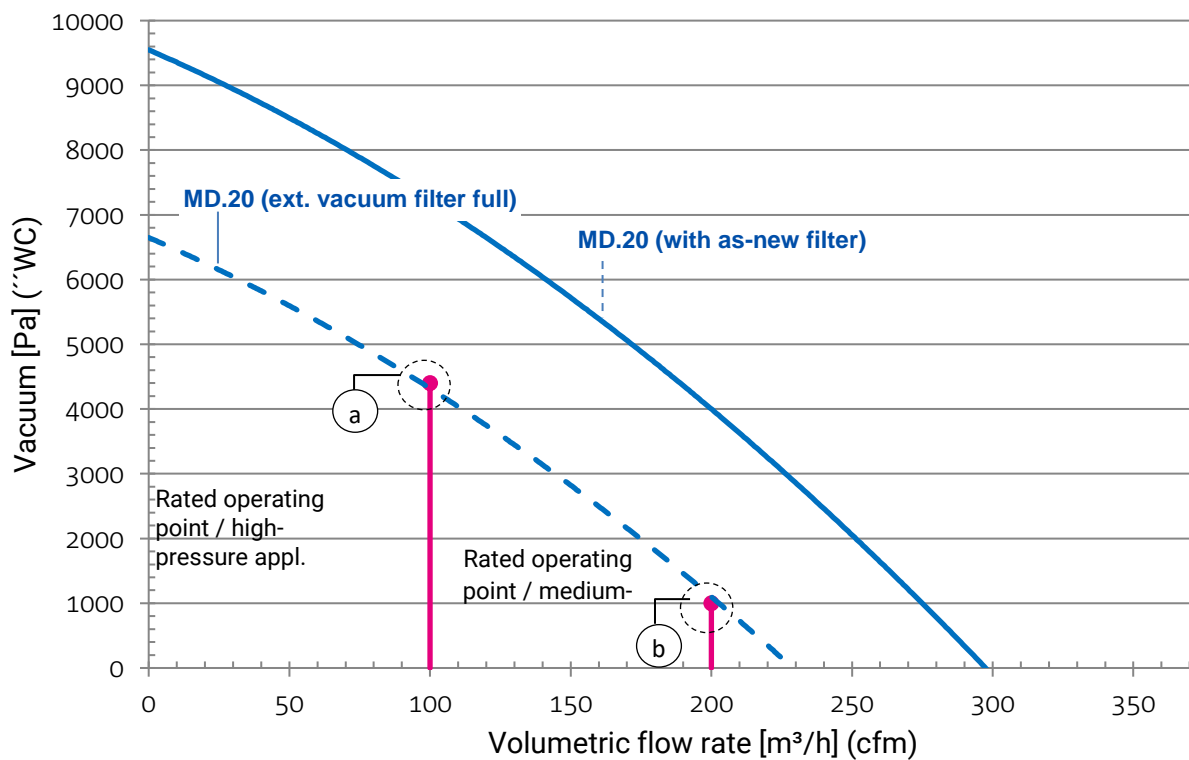



S3 switch for ecoflow CS®:

- **S3** switch is in the position “0”
 - ecoflow CS® “OFF”

Control range of the potentiometer in position “0”

The suction power can be individually adjusted via the potentiometer on the front of the unit. Clockwise rotation allows you to continuously increase the suction power, while counter-clockwise rotation continuously reduces the suction power.

The rotational speed of the blower can freely adjusted up to the maximum rotational speed.

- **S3** switch is in the position “I” or “II”
 - ecoflow CS® “ON”

Control range of the potentiometer

Vacuum operation between 120 Pa - 5,000 Pa (0.48 - 20.09``WC)

Suitable up to a suction power of 230 m³/h (135.37 cfm)

Remote operation

In remote mode, the Extraction and Filtration System LAS 260.1 can be controlled by a higher-level machine via the communication interface M12.

The higher-level machine can then switch on the LAS 260.1 and set it into standby mode.

Prerequisite for remote operation:

- The higher-level machine is connected via the communication interface **M12** to the LAS 260.1.
- **S2** switch is in the position “0”

The operator can still adjust the suction power by hand on the potentiometer and switch on the ecoflow CS[®] via the **S3** switch (see section **ecoflow CS[®]**).

NOTICE

If no higher-level machine is connected, the **S2** switch must be in the position “1.”

The time interval between switching on and switching off should be at least 5 minutes. Otherwise, there is a risk that the blower might be damaged.

Shutdown

When shutting down the LAS 260.1, always follow the safety instructions in these operating instructions.

- Switch off the unit.
- Disconnect the electrical connections of the LAS 260.1.



Maintenance and servicing

General maintenance and servicing instructions

Maintenance of the device is limited to the inspection and replacement of the filter elements. Maintenance and inspection work must be performed at regular intervals. It is the responsibility of the user of the unit to find out which rules and regulations apply to the particular application or country, such as the German Social Accident Insurance (DGUV), and to make sure that these are applied. Written records must be kept about the work performed; these records shall be submitted to the supervisory authorities on demand.

Daily inspection

- Check of the particulate filter status and replacement of the filter element as required.

Monthly inspection

- Check of the suction pipe system
- Check of the collection device

Yearly main inspection

- By arrangement with ULT AG the main inspection can be performed by ULT Service.

By arrangement with ULT AG, further measures that go beyond the scope of the points outlined above can be performed by ULT Service.

 **DANGER**



For your own safety always wear personal protective equipment during all maintenance and servicing work. As a minimum, this should include respiratory protection (filter category P3) and protective gloves.

 **DANGER**

Before starting any work, switch off the unit and secure it so that it cannot be switched back on inadvertently. Wait for the blower to come to a standstill.

After all maintenance work, always clean the working area in which the work was performed.





Only perform maintenance work when the system is completely de-energized and there are no live voltages present. Observe the following points in the process:

- Switch off the unit and secure it so that it cannot be switched back on again.
- Wait for the blower to come to a standstill.
- Disconnect the mains plug.

Filter change

Maintenance of the device is limited to the inspection of filter saturation and replacement of the filter.

The LED status ring indicates the status of the particulate filters (pre-filter and main filter). Filter saturation can also be reported via the M12 interface to a higher-level control.

Color code	Status
<p>Green</p>  <p>The diagram shows a circular LED status ring with a green inner ring and a blue outer ring. The ring is labeled 'MIN' on the left and 'MAX' on the right.</p>	<ul style="list-style-type: none"> • Particulate filters are OK.
<p>Orange</p>  <p>The diagram shows a circular LED status ring with an orange inner ring and a blue outer ring. The ring is labeled 'MIN' on the left and 'MAX' on the right.</p>	<ul style="list-style-type: none"> • Particulate filters are heavily saturated. • The particulate filters need to be replaced soon.
<p>Red</p>  <p>The diagram shows a circular LED status ring with a red inner ring and a blue outer ring. The ring is labeled 'MIN' on the left and 'MAX' on the right.</p>	<ul style="list-style-type: none"> • The particulate filters are completely saturated and must be replaced immediately. • To start with, only replace the pre-filter. If the situation does not improve after replacement, then change the main filter.

NOTICE

The saturation of the adsorption filter is not indicated via the LED status ring.

After a certain period of time, depending on the level of pollutants/impurities present the activated carbon will become saturated. The time until saturation occurs needs to be determined, and the filter should then be regularly replaced whenever this time limit is reached. If the gases that are supposed to be separated out are noticeably present in the outlet air stream, change the adsorption filter immediately.

⚠ DANGER



During all work on the opened unit, substances that are harmful to health can be released from the filter elements and come into contact with persons.

Any released dusts must be removed with an extraction device that has at least the same filter class as this unit and is equipped with a suitable collection device.

The storage filter elements used in the unit are not suitable for cleaning with compressed air. If the filters are blown out with compressed air, this will destroy the filter membrane and release any dusts already collected.

Replacement of the pre-filter stage

NOTICE

If the filter saturation indicator shows that the filter needs to be replaced, as the first step it is only necessary to replace the pre-filter stage. If the situation does not improve after replacement, then change the main filter.

To change the filter proceed as follows:

1. Switch off the unit and disconnect the mains plug.



2. Open the door catch on the left-hand side of the unit.



3. Open the filter chamber door.



4. Take out the saturated filter and place it in a suitable disposal container that can be sealed airtight.



CAUTION

When taking out the filter, support the frame from underneath to prevent injuries caused by it falling down.

Replacement of the main filter

- Lift out the saturated main filter to the top, holding it by the grip tabs ①. Then pull it out to the front ② and place it in a suitable disposal container that can be sealed airtight.

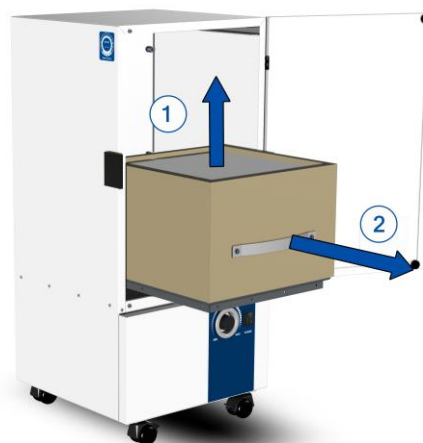

 **WARNING**

Note the heavy weight of the filters (> 15 kg / 33 lb – see filter label). Take special care to ensure that the filter does not fall down.

Filter installation

- Before installing the new filter, make sure that the bottom plate ① in the filter compartment is free of dirt or soiling.



7. Insert the new main filter cassette. Make sure that the seal on the underside of the filter cassette is not damaged in the process.

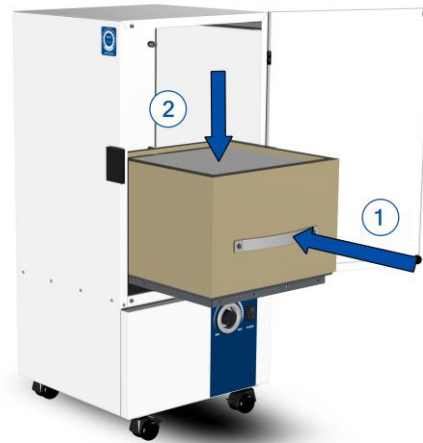

8. Insert the new pre-filter cassette. Make sure that the seal on the rear of the filter cassette is not damaged in the process.



9. Close the filter chamber door.



10. Close the door catch again.



11. Reconnect the mains plug.

 **DANGER**

NOTICE

Never use the unit if it is damaged or incomplete.

The owner of the waste, which in this context is normally whoever generates the waste, is responsible for proper recycling or disposal of the waste. The operator is responsible for the waste that accumulates and for the soiled filters.

The saturated filters must be properly disposed of in accordance with the applicable regional regulations.



Optional outlet nozzle

For the LAS 260.1 it is possible to mount the outlet grille instead of the outlet nozzle. The filtered air can be directed via the outlet nozzle into an air outlet system.

Tools required

- 2.5 mm hexagon socket screw key

Remove the eight M4x12 screws on the rear of the unit and take off the outlet grille.



Rotate the air outlet adapter through 180 degrees.



Mount the outlet nozzle on the enclosure using the eight previously removed M4x12 screws. Make sure that the seal on the outlet nozzle is not damaged in the process.



LED status messages

Status white



Standby mode

Continuously on:

The unit is waiting for a signal from a higher-level machine or from an optionally available pedal switch.

NOTICE

This message is only output if the **S2** switch is in the "0" position.

Status green



**No errors
Notifications**

Flashing:

This status is only output in the operating mode ecoflow CS[®]. The set suction power is not currently being attained by the unit.
The device is running outside of the unit specifications.

NOTICE

- Connect the suction section.
- Reduce the diameter of the suction section.
- Check the suction power and slowly reduce it if required via the potentiometer until the LED status ring stays continuously green.



Continuously on:

The unit is running normally within the parameters set by the user.

The saturation of the adsorption filter is not indicated via the LED status ring.

Status orange

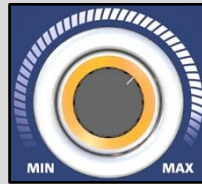

Warning

Continuously on:

Particulate filters are heavily saturated. The particulate filters need to be replaced soon.

Get new filters ready for replacement.

NOTICE

Status red



Critical message

Flashing:

The unit is unable to detect volumetric flow across the filters. It is possible that no filter is installed in the unit. The particulate filters are not correctly seated in the unit. The intake is possibly blocked. The set volumetric flow rate is too low. The blower is possibly defective.

NOTICE

- Insert a particulate filter.
- Check the particulate filter for damage and correct seating.
- Check the intake section for free passage.
- Increase the set volumetric flow rate.
- Have the blower checked.

Continuously on:

The particulate filters are completely saturated.

NOTICE

Carry out a particulate filter change as described in the section "Maintenance and servicing."



Potential malfunctions

Error	Possible cause	Remedy
Fan not starting up		
	No power supply to the unit	Check the power supply at the mains outlet.
	Fault in the unit/control electronics	Have repairs carried out by a specialist (specialist dealer)
	Defective unit fuse	Replace the fuse
	Signal for remote ON/OFF not present	Check the interface M12 and the bridge switch
Inadequate suction and filter performance		
	Air passage obstructed	Check the suction path and the outlet air guidance
	Filters are saturated	Check the filter saturation indicator, replace the filter(s)
Poor filtration		
	Filters are saturated	Check the filter saturation indicator, replace the filter(s)
	Filters are not in the correct position	Check the seating of the filters

Replacement and wear parts

Description	Item number
Replacement parts	
Hinge	3-01306
Potentiometer / filter saturation indicator	3-00181
Fuse 5x20 mm 10 A slow	6-04127
Protective cap rocker switch	6-03859
Protective cap M12 black	6-09330
Caster with wheel lock	6-00027
Vibration damper (device foot)	6-04511
Outlet air adapter	3-01273
Wear parts	
Vacuum generator	3-00302

NOTICE

When placing an order, please always quote the item number.

In order to maintain the operational safety and reliability of the unit, always use genuine replacement parts from ULT AG. If replacement parts from third parties are used, all guarantees and warranty claims will be voided for the unit.

Filter list

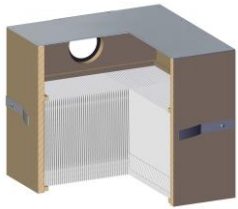
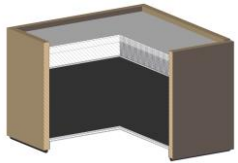
Type	Description	Item number
Pre-filter		
	Particulate filter cassette F9	4-00107
Main filter		
	Combined filter cassette H14A10	4-00109

NOTICE

Only use genuine filters from ULT AG. This is the only way to ensure that the stated filter performance can be achieved.

Contact:

Global ULT AG Am Göpelteich 1 02708 Löbau, Germany Tel.: 0 35 85 / 41 28 0 Fax: 0 35 85 / 41 28 11 E-mail: ult@ult.de	North America ULT Canada Sales Incorporated 64111 - 393 Avenue East, Suite E57 Okotoks, AB, T1S0L1 Canada Tel.: +1 866-694-1131 E-mail: office@ult-na.com
----------------------------------------------------------------------------------------------------------------------------------------------------	----------------------------------------------------------------------------------------------------------------------------------------------------------------------------------------------

Service

The following services are available:

- Supply of accessories
- Supply of spare parts
- Supply of replacement filters
- Ongoing maintenance
- Performance of any necessary repairs
- Disposal of the unit

ULT AG
Am Göpelteich 1
OT Kittlitz
D-02708 Löbau



EU - Declaration of Conformity

according to Machinery Directive 2006/42/EG annex II No. 1A

Herewith, we declare that the following product type in its delivered state complies with the following relevant provisions:
EC-Machinery directive 2006/42/EG
Electromagnetic compatibility - directive 2014/30/EU

If the above mentioned machine is technically modified without our approval, this declaration shall no longer be applicable:

Description of machine:	extraction and filtering unit
Type:	<u>LAS 260.1</u>
Series No.	<u>YYYY 14 xxxx</u> (Year - Type/Serial - Number)
Applied national technical standards and specifications:	DIN EN ISO 12100 DIN EN ISO 13857 DIN VDE 1000 DIN EN 60204-1

Karl Ullwer is the authorized representative for completion of the technical documentation
Address: ULT AG
Karl Ullwer
Am Göpelteich 1
D-02708 Löbau

place, date Löbau, 26.06.2023

signature:

T. Heinitz
T.Heinitz / Research & Development

ULT AG
Am Göpelteich 1 - OT Kittlitz
D - 02708 Löbau
Telefon +49(0)3585 / 41 28 - 0
Telefax +49(0)3585 / 41 28 11
ult@ult.de www.ult.de

Design A: Internal power supply

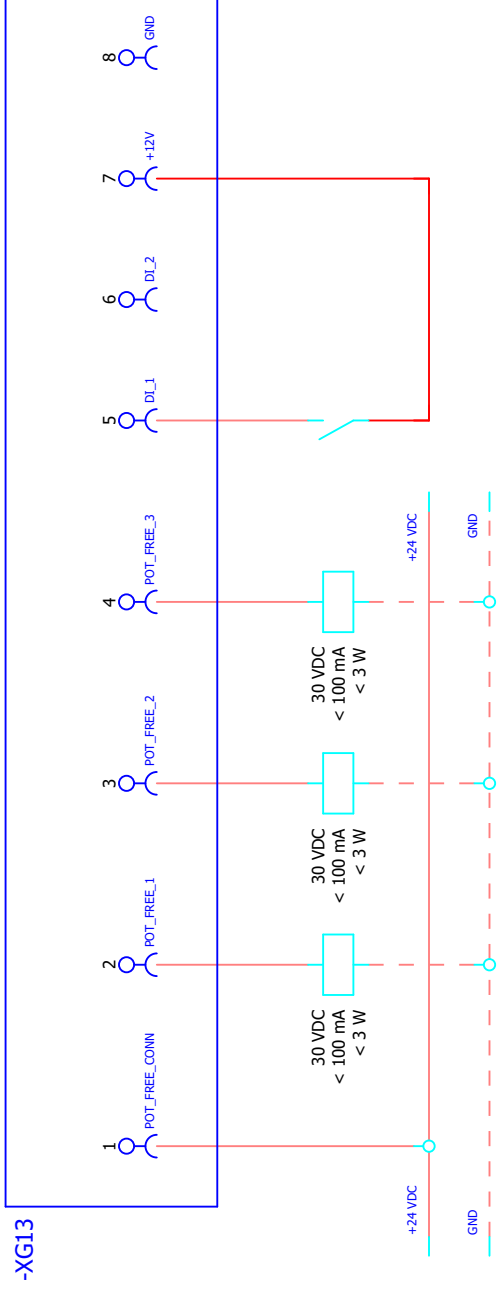

Design B: External customer power supply

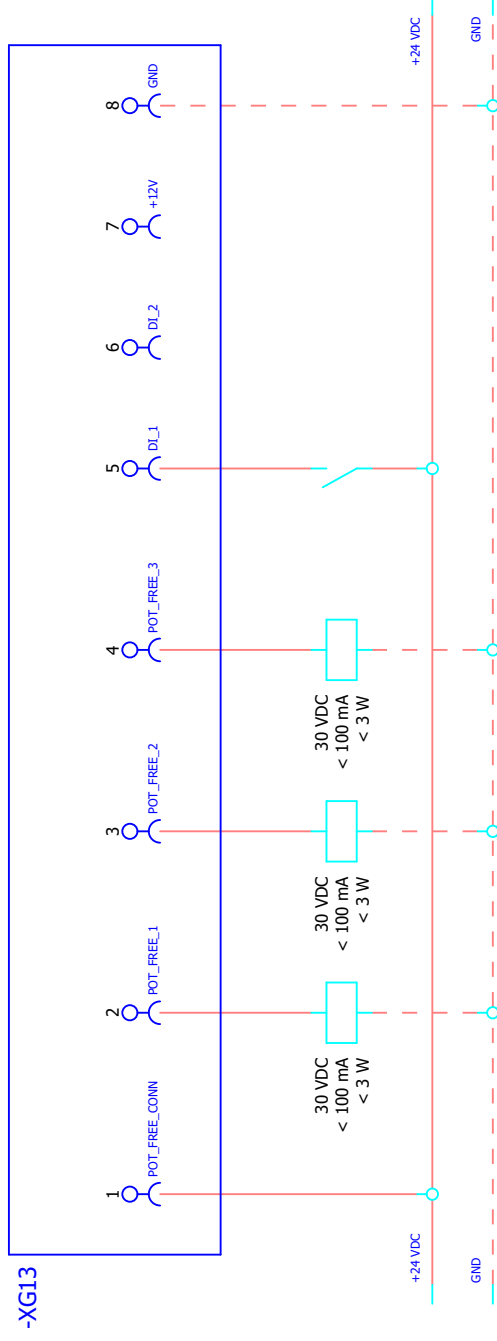

XG13 DIN EN 61076-2-101 / M12 / A-coded / 8-pin / Female

PIN	Function	Potential	Rating	Status	Description
1-2	Status operation (1)	Potential free	< 30 VDC < 100 mA	Open	Machine out of operating
1-3	Status filter (1)	Potential free	< 30 VDC < 100 mA	Open	Filter 80% depleted
				Closed	Filter OK
1-4	Status filter (1)	Potential free	< 30 VDC < 100 mA	Open	Filter 100% depleted
				Closed	Filter OK
5-7	Remote ON/OFF (2)	24 VDC	High	Maschine ON	
			Low	Maschine OFF	

Note (1): Signals are only to be evaluated when the unit is connected to supply voltage and the main switch is ON.

Note (2): Control with internal power supply (pin 7) or with external customer power supply (max. 24 VDC). The GND from the external power supply must be connected to the GND from the machine (pin 8).



